

Erbium Doped Fiber Amplifier

1528-1565nm up to 26dBm, 1535-1565nm up to 41dBm



DATASHEET

[Return to the Webpage](#)



Features

- Low Noise
- High Output Up to 41dBm
- High Stability
- High Reliability
- Customizable

Applications

- BOTDR
- OTDR
- LiDAR
- Fiber sensing

Agiltron's Erbium-Doped Fiber Amplifier (EDFA) is a cost-effective solution for optical signal amplification, utilizing high-reliability semiconductor lasers, Wavelength Division Multiplexing (WDM) components, isolators, and erbium/ytterbium-doped fibers to deliver high power output, gain, low noise, and long operational life. Available in both preamplifier and booster configurations, the EDFA supports polarization-maintaining and random polarization versions with multiple packaging options. It features a compact module with a universal control interface PCB for system integration, as well as a turnkey benchtop model with a computer interface and GUI for laboratory use. A pluggable model with a standardized host rack is available for network deployments. For power levels below 25dBm, the EDFA covers a wavelength range from 1528-1565nm, while for higher power levels, the wavelength range reduces to 1535-1565nm. For longer wavelength needs, L-band amplifiers are recommended.

Special EDFAs are also available for pulse applications with long periods. For EDFAs with a power of less than 26 dBm, a gain flattening filter can be added.

The EDFA operates in ACC (Automatic Current Control) mode, where the pump laser current is user-set and stabilized for constant pumping, and APC (Automatic Power Control) mode, which maintains constant output power even during input fluctuations. Special CC (Constant Current) mode is settable in which the pump laser current is always on regardless of input signal level. Engineered for reliability, the EDFAs are built for over 10 years of operation, featuring high-quality components, advanced thermal management, and rigorous testing to ensure efficiency and performance in demanding environments.

Specifications

Parameter		Min	Typical	Max	Unit
Wavelength		1530	1550	1565	nm
Input Power	Booster <= 24dBm	-30	0	10	dBm
	Booster > 24dBm	-5		10	dBm
	Pre	-30	-20	5	dBm
Output Power	Booster			41	dBm
	Pre			25	dBm
Optical Gain	Booster			40	dBm
	Pre			40	dBm
Noise Figure			5 [6]		dB
Gain Flatness			1		dB
Polarization Dependent Gain [4]				0.3	dB
Polarization Mode Dispersion [4]			0.5		ps
Input/output Isolation		35			dB
Output Stability (8hrs)			0.05	0.1	dB
Adjustable Output Power			Yes with AGC		
Fiber Type		SMF-28e 9/125um NA = 0.13			
Working Temperature [1]		-30	40	70	°C
Storage Temperature		-40		85	°C
Power Consumption				25	W
Power Supply	< 23dBm (MSA)		DC +5		V
	≥ 23dBm		DC +12		V
Communication			USB / RS232/		

Notes:

[1]. The regular range is -5 to 40°C, for extended range requires additional cost

Note: The specifications provided are for general applications with a cost-effective approach. If you need to narrow or expand the tolerance, coverage, limit, or qualifications, please [click this link](#):

Legal notices: All product information is believed to be accurate and is subject to change without notice. Information contained herein shall legally bind Agiltron only if it is specifically incorporated into the terms and conditions of a sales agreement. Some specific combinations of options may not be available. The user assumes all risks and liability whatsoever in connection with the use of a product or its application.

Rev 11/15/24

Erbium Doped Fiber Amplifier

1528-1565nm up to 26dBm, 1535-1565nm up to 41dBm



DATASHEET

Function Diagram

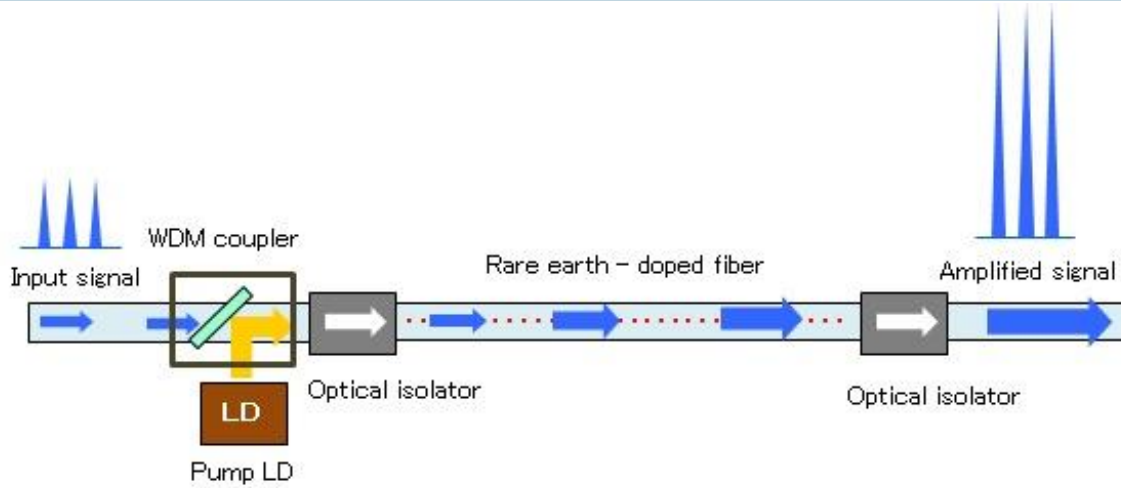

Package Choices



Component



Benchtop- USB/GUI

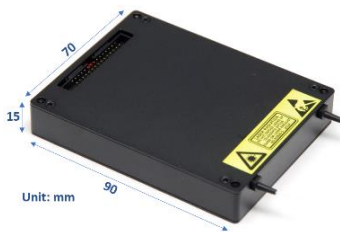

MSA



MSA USB/GUI Adapting PCB

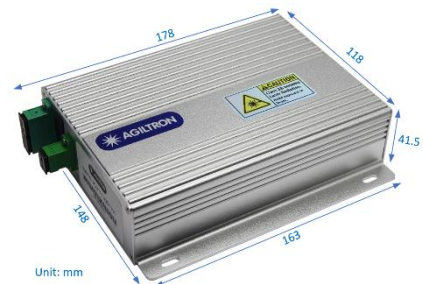

Mini benchtop



Net-Control Rack

Erbium Doped Fiber Amplifier

1528-1565nm up to 26dBm, 1535-1565nm up to 41dBm



DATASHEET

GUI USB Interface

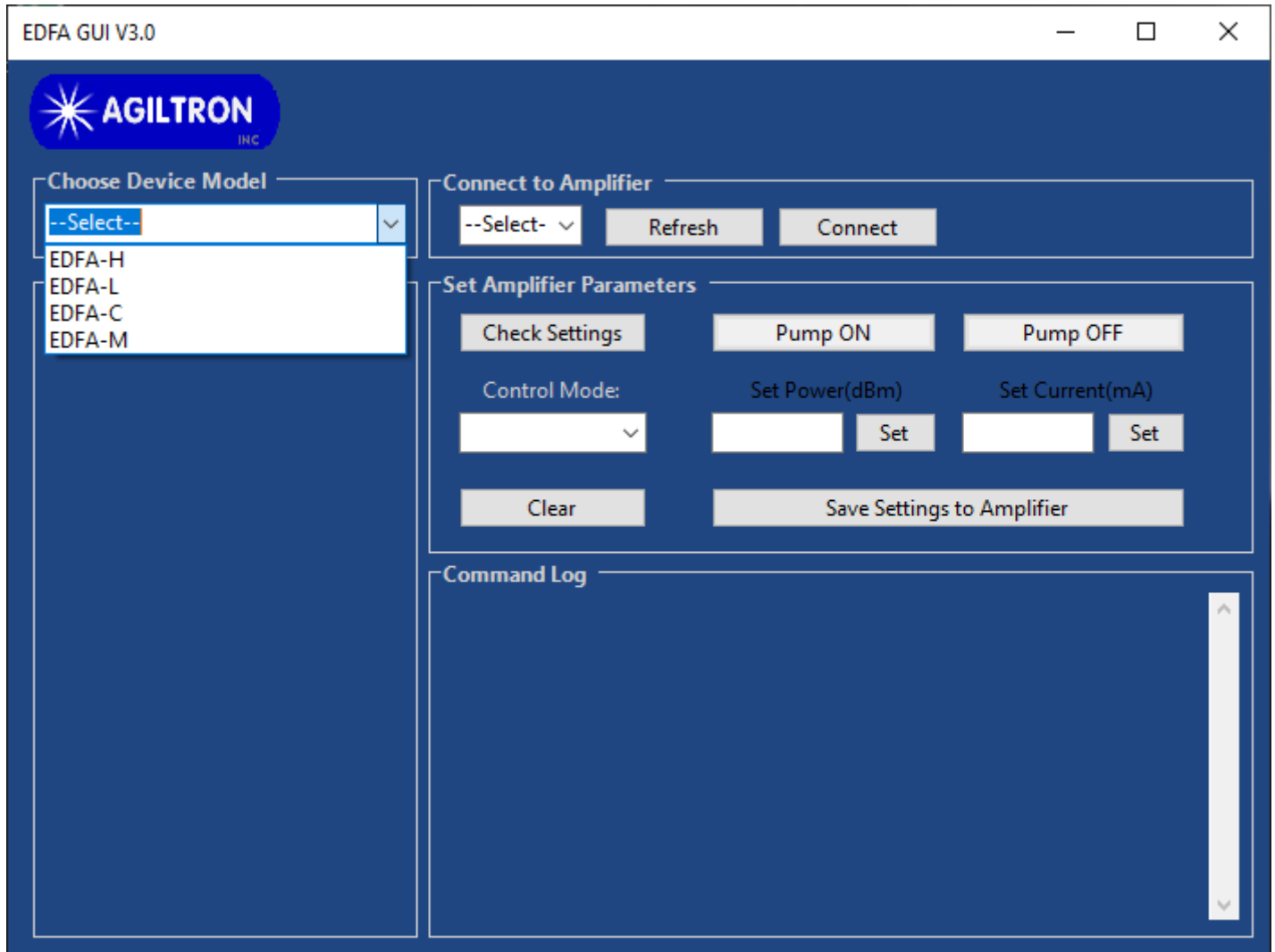

Operation Instruction

- Load the software, Unzip the folder and Click "setup" to Install the GUI
- Select an amplifier type that matches your PO
- Connect your PC to the Amplifier by first connecting a USB cable and then choosing the necessary port and clicking "Connect". To change the COM port click "Refresh", choose the necessary port, then click "Connect"
- Obtain the stored settings by clicking "Check Settings"
- To change the setting, first select the control mode
- To set up output power or current, input desired value and click "Set". There are limits for max output per the model type.
- To turn on the Amplify click "Pump ON"; the green color should appear. To stop click "Pump OFF"; the red color should appear
- To save the setting click "Save Settings to Amplifier". The Amplifier will store the setting for the next time you turn it on, even without the PC.
- The Amplifier only works if the input optical power level is within the spec.

Erbium Doped Fiber Amplifier

1528-1565nm up to 26dBm, 1535-1565nm up to 41dBm



DATASHEET

Control GUI

Erbium Doped Fiber Amplifier

1528-1565nm up to 26dBm, 1535-1565nm up to 41dBm



DATASHEET

Output Power Stability (33dBm Benchtop)

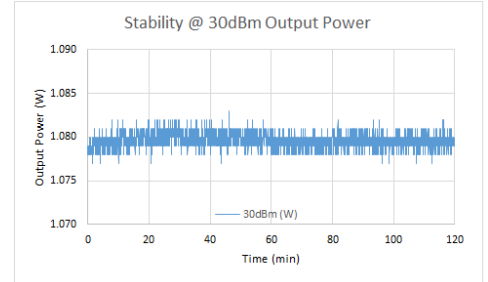
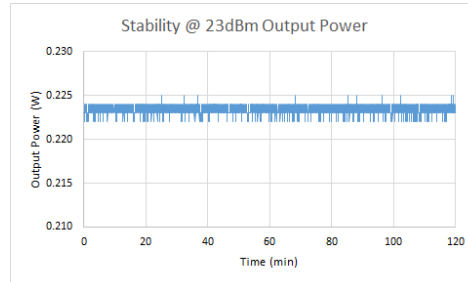
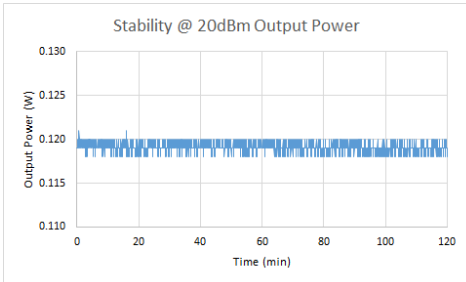

Mechanical Dimensions (mm)

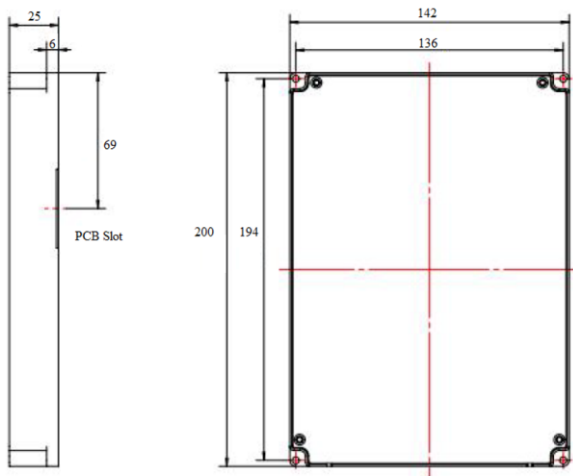

High-power: >23dBm

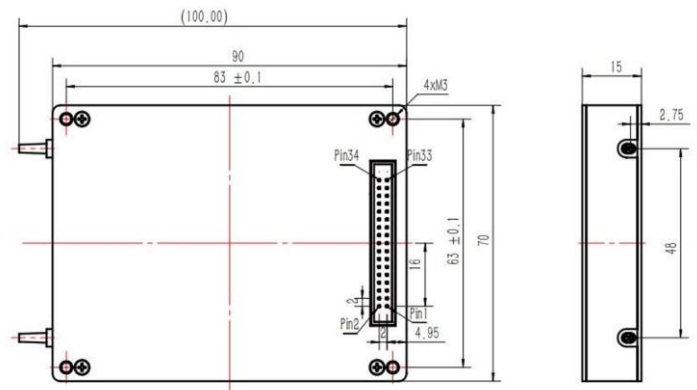

MSA package: 20dBm

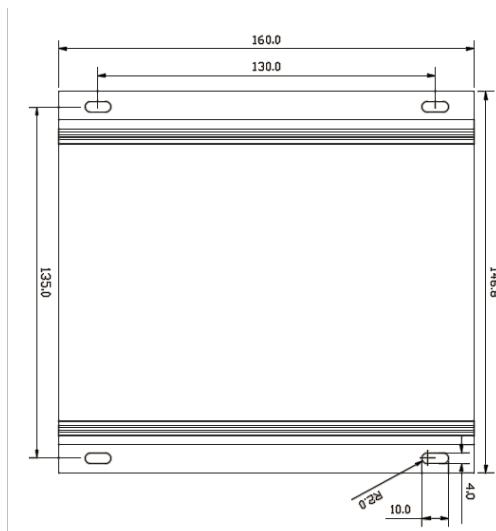

Mini Benchtop: 17/20dBm

*Product dimensions may change without notice. This is sometimes required for non-standard specifications.

Erbium Doped Fiber Amplifier

1528-1565nm up to 26dBm, 1535-1565nm up to 41dBm



DATASHEET

Mechanical Dimensions (mm)

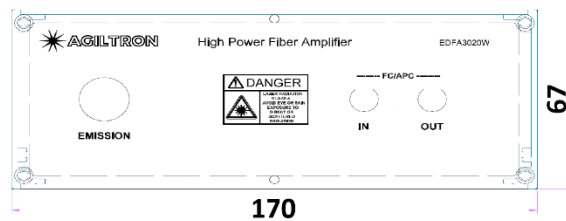
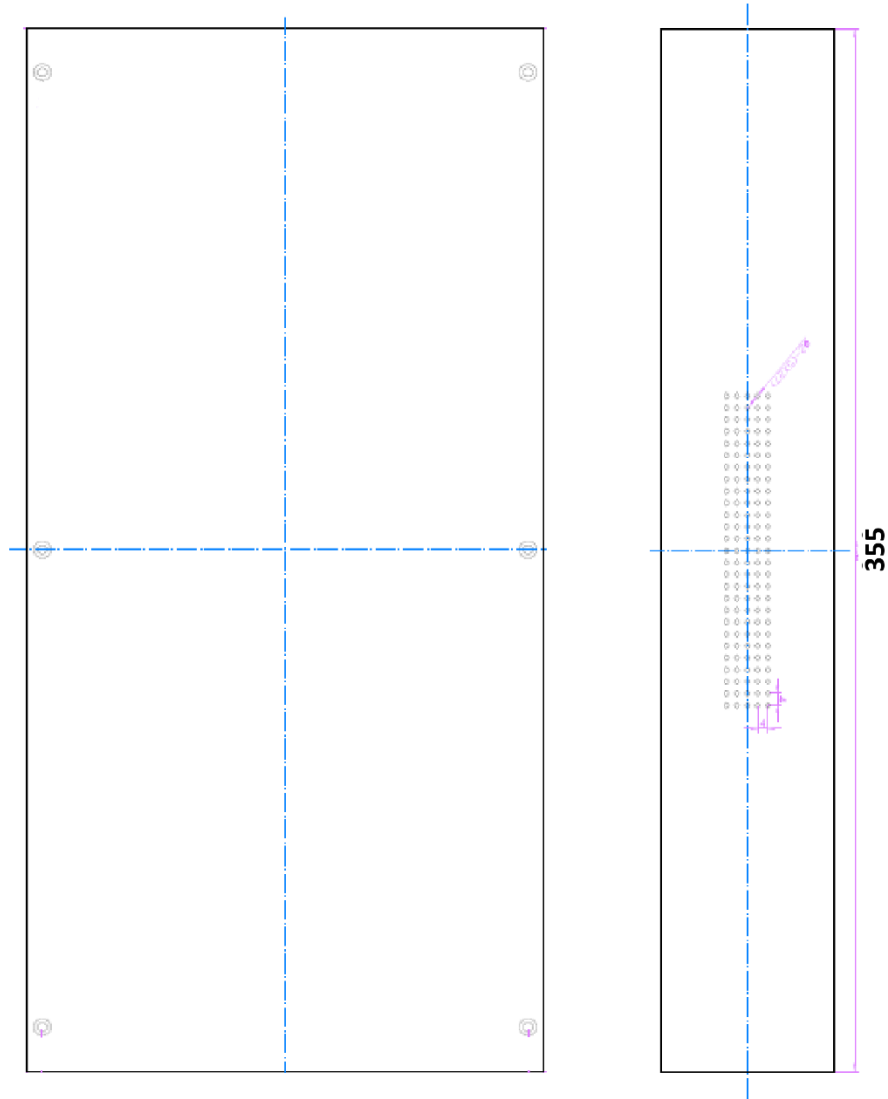

Mid-size
Benchtop

*Product dimensions may change without notice. This is sometimes required for non-standard specifications.

Erbium Doped Fiber Amplifier

1528-1565nm up to 26dBm, 1535-1565nm up to 41dBm



DATASHEET

Mechanical Dimensions (mm)

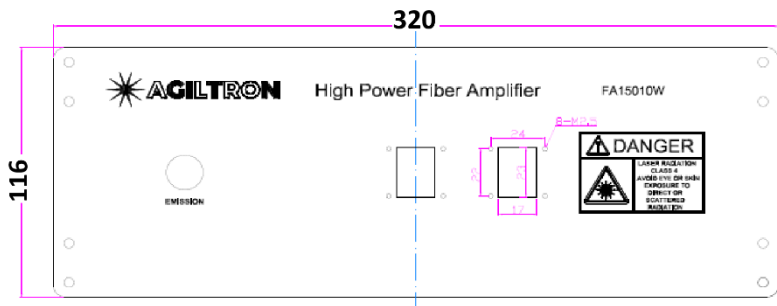
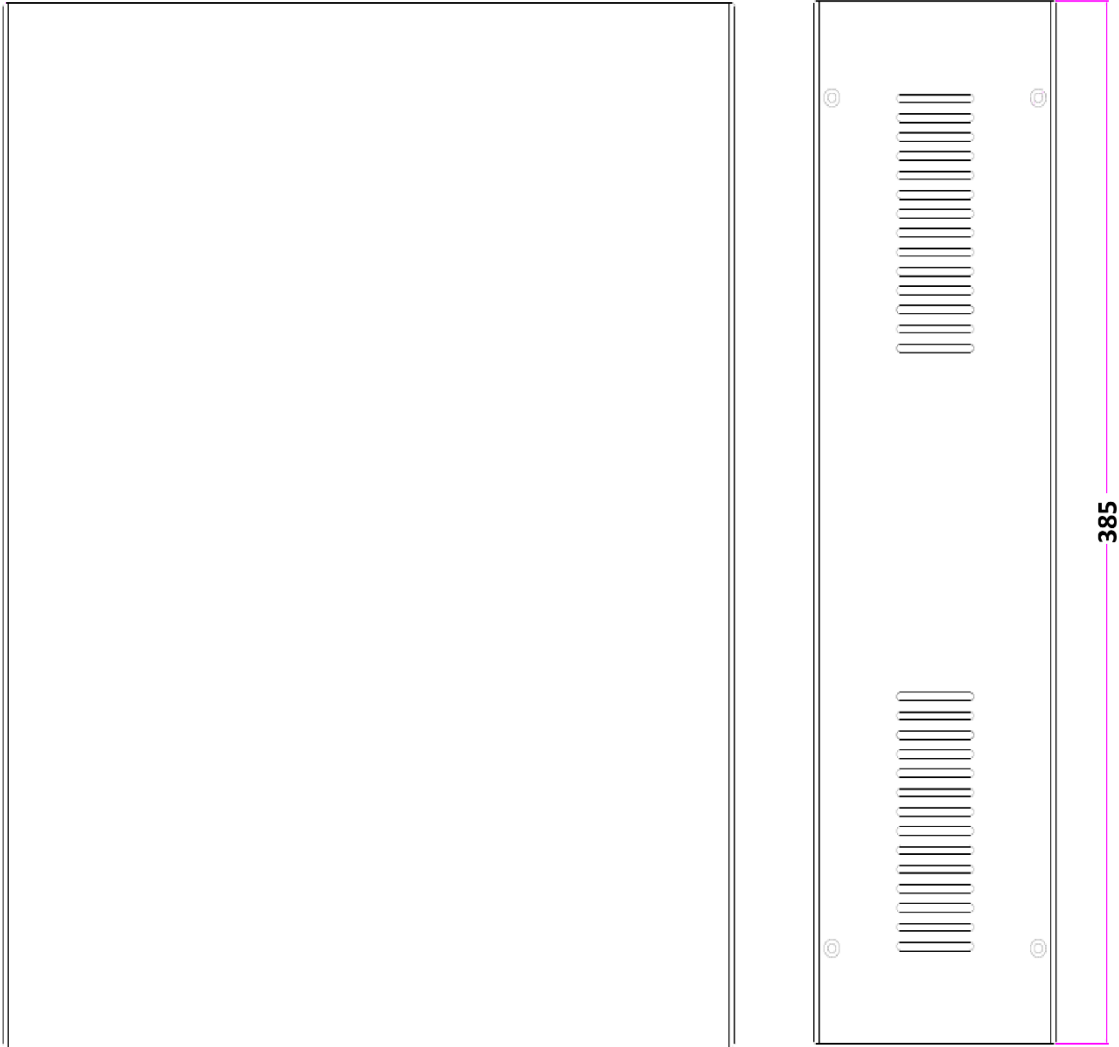

Large-size
Benchtop

*Product dimensions may change without notice. This is sometimes required for non-standard specifications.

Erbium Doped Fiber Amplifier

1528-1565nm up to 26dBm, 1535-1565nm up to 41dBm



DATASHEET

Ordering Information

Prefix	Type	Wavelength	Power/Gain ^[1]	Output Channel	Polarization	Package	Cable Type	Fiber Length ^[4]	Connector ^[5]	Low Temperature	High Temperature	Control Mode	Filter ^[6]
EDFA-	Booster =1 Preamp =2	1528-1565nm<26dBm 1535-1565nm>26dBm	17dBm/50mW = 2 20dBm/100mW = 3 30dBm/1W = 1 33dBm/2W = 5 37dBm/5W = 7 40dBm/10W = 8 41dBm/12W = 9 Special = 0	One = 1	Random = 1	Component = 1 Benchtop = 2 EYA = 3 MSA = M MSA/USB ^[3] = H Mini Benchtop = A Special = 0	0.9mm tube = 3 Special = 0	0.25m = 1 0.5m = 2 1.0m = 3 Special = 0	None = 1 FC/PC = 2 FC/APC = 3 SC/PC = 4 SC/APC = 5 LC/PC = 7 LC/APC = A LC/U/PC = U High Power FC/PC = H Special = 0	-5°C = 1 -30°C = 2 Special = 0	40°C = 1 70°C = 2 Special = 0	APC = 1 ACC = 2 CC = 3 Special = 0	None = 1 Gain flat = 2 Special = 0

[1]. For Booster, maximum output power. For Preamp, maximum amplification gain.

[2]. This is a low cost version with mini benchtop package only having no power adjustment capability, please order 20dBm for Benchtop.

[3]. The MSA mounted on a USB adapting PCB. Comes with GUI and power supply

[4]. For >1W modules, the fiber cables extrude out of the front.

[5]. **Regular connector only rated to 0.5W and will burn at higher power. We make a special beam expanded connector to handle up to 5W. For output >1W, only bare fiber or HPFC is available. HPFC is only sold in pairs. The high-power FC/PC connector and a matching patch cable with one end high-power connector and the other end bare fiber for splicing is \$950.**

[6]. Only available for power <26dBm

Note:

- Preamplifier output power is limited to 25dBm

Application Notes

Fiber Core Alignment

Note that the minimum attenuation for these devices depends on excellent core-to-core alignment when the connectors are mated. This is crucial for shorter wavelengths with smaller fiber core diameters that can increase the loss of many decibels above the specification if they are not perfectly aligned. Different vendors' connectors may not mate well with each other, especially for angled APC.

Fiber Cleanliness

Fibers with smaller core diameters (<5 μm) must be kept extremely clean, contamination at fiber-fiber interfaces, combined with the high optical power density, can lead to significant optical damage. This type of damage usually requires re-polishing or replacement of the connector.

Maximum Optical Input Power

Due to their small fiber core diameters for short wavelength and high photon energies, the damage thresholds for device is substantially reduced than the common 1550nm fiber. To avoid damage to the exposed fiber end faces and internal components, the optical input power should never exceed 20 mW for wavelengths shorter 650nm. We produce a special version to increase the how handling by expanding the core side at the fiber ends.

Erbium Doped Fiber Amplifier

1528-1565nm up to 26dBm, 1535-1565nm up to 41dBm



DATASHEET

Laser Safety

This product meets the appropriate standard in Title 21 of the Code of Federal Regulations (CFR). FDA/CDRH Class 1M laser product. This device has been classified with the FDA/CDRH under accession number 0220191. All versions of this laser are Class 1M laser products, tested according to IEC 60825-1:2007 / EN 60825-1:2007. An additional warning for Class 1M laser products. For diverging beams, this warning shall state that viewing the laser output with certain optical instruments (for example eye loupes, magnifiers, and microscopes) within a distance of 100 mm may pose an eye hazard. For collimated beams, this warning shall state that viewing the laser output with certain instruments designed for use at a distance (for example telescopes and binoculars) may pose an eye hazard.

Wavelength = 1.3/1.5 μ m.

Maximum power = 30 mW.



*Caution - Use of controls or adjustments or performance of procedures other than those specified herein may result in hazardous radiation exposure.
*IEC is a registered trademark of the International Electrotechnical Commission.

Q&A About Fiber Optical Amplifier

Q: Can this amplifier pulsed signals?

A: It has been tested to amplify up to 100GHz digital data.

Q: Can this amplifier WDM signals?

A: It has been tested to amplify signals with DWDM wavelength spacing.

Q: Can this amplifier has a flat wavelength response?

A: Yes, by put fluttering gain filters, that is an extra cost.

Q: If one puts a small signal into it, can it be amplified to the maximum output power indicated on the spec?

A: The amplifier is set as an analog mode whose output signal strength is approximately proportional to the input strength. It has a certain gain of about 40dB. There are two types: one is a preamplifier and a booster. One can use a preamplifier before the booster for weak signals, as done in electronic amplifiers.

Q: We have an existing amplifier. Can you duplicate it?

A: Yes, we can produce it with a seamless software interface.

Q: The control mode is selectable in the GUI, does this mean it can be operated in either APC, ACC, or CC mode? (i.e. can you support all 3 control modes in a single system)

A: MSA EDFA: APC, ACC & CC (AGC)
EYDFA (MSA & standard) : APC & ACC

Q: Do the MSA packages work with the Agiltron GUI?

A: Yes

Q: Do you have preamplifier with -35 and -40dBm input power?

A: Yes, available in different package.

Q: Does the Preamplifier come with APC or ACC control mode and which control mode achieves better receive sensitivity?

A: Under ACC mode, EDFA will amplify any input if you choose the always-on pump option.

Q: If we want to control the EDFA without the GUI, do you have a list of the RS232 commands?

A: It comes with each EDFAs.

Erbium Doped Fiber Amplifier



1528-1565nm up to 26dBm, 1535-1565nm up to 41dBm

DATASHEET

Modes Description

The EDFAs have both ACC mode - automatic current control or constant current control and APC mode - automatic power control settable via GUI. In the ACC mode, the pump laser's current is set by the user and automatically locked by the EDFA to achieve a constant pumping current. The EDFA's output power is proportional to the input power and has output even though the input signal is weak. In the APC mode, the user sets the output power, and the EDFA automatically maintains the output constant in a feedback laser pump control way. When the input optical power fluctuates, the APC mode minimizes the fluctuation of the output power and is suitable for power type and line type EDFA.

Typical Spectrums

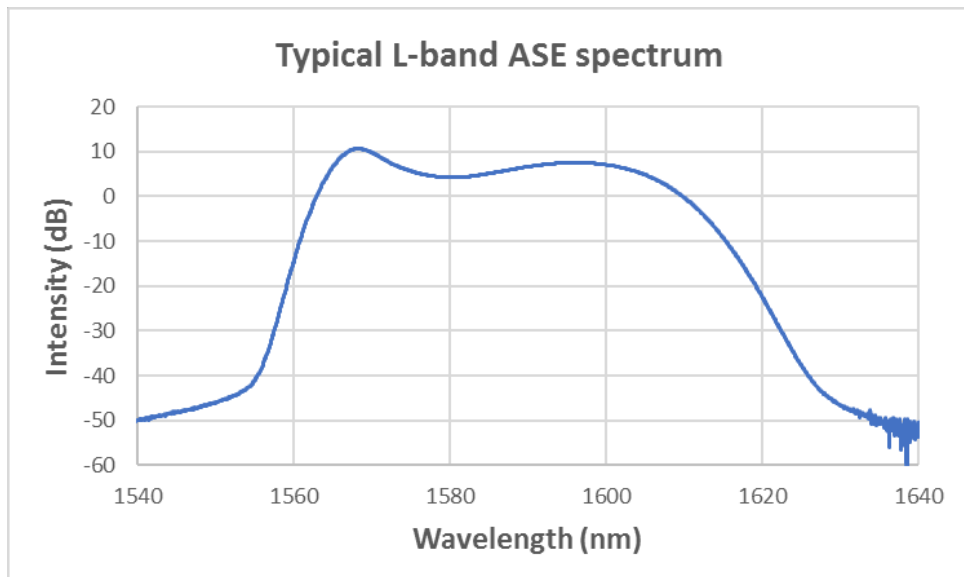
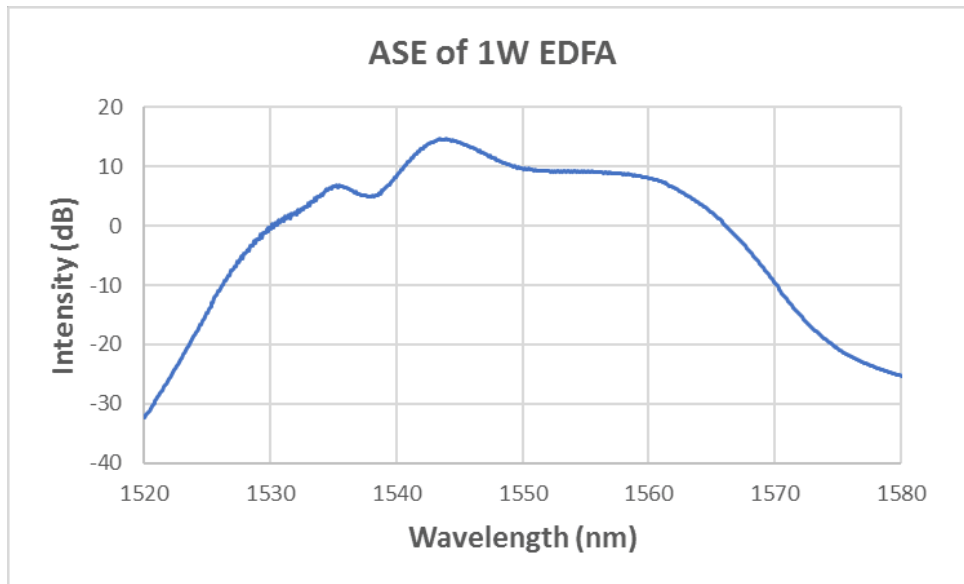

Erbium Doped Fiber Amplifier

1528-1565nm up to 26dBm, 1535-1565nm up to 41dBm



DATASHEET

Typical Nanosecond Laser Pulse Amplification

- Source laser: 2.5kHz 200ns pulses with peak power 1.33mW
- Amplified 42dB by 23.5dBm EDFA;
- ASE floor is about 24dB lower than the peak power;

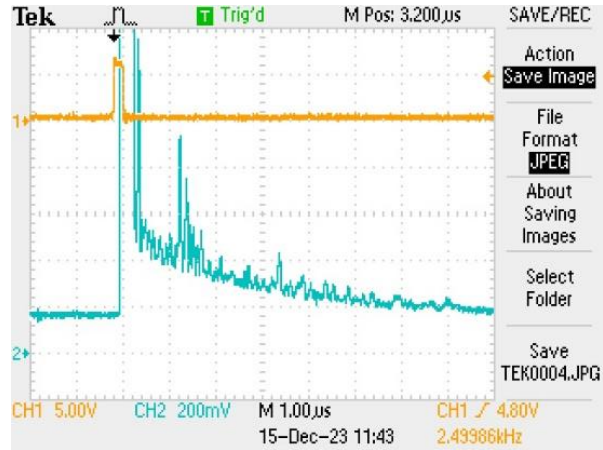
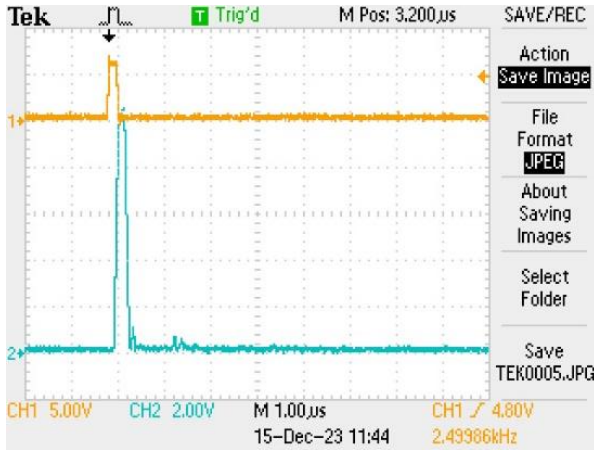

Gain Flattering Filter Effect <25dBm

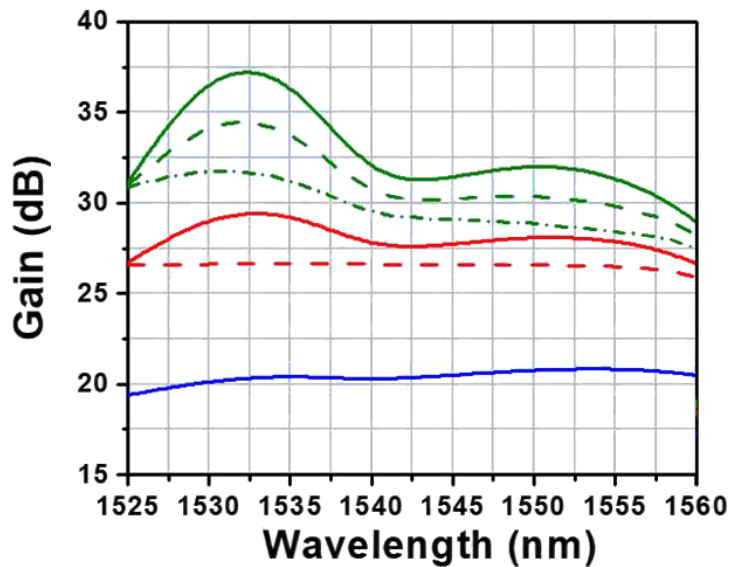

- 0 dBm Without Gain Flattering Filter
- -10 dBm Without Gain Flattering Filter
- - -10 dBm With One Gain Flattering Filter
- -20 dBm Without Gain Flattering Filter
- - -20 dBm With One Gain Flattering Filter
- · - · -20 dBm With Two Gain Flattering Filter

Information contained herein is deemed to be reliable and accurate as of the issue date. Photonwares reserves the right to change the design or specifications at any time without notice. Agiltron is a registered trademark of Photonwares Corporation in the U.S. and other countries.

Erbium Doped Fiber Amplifier

1528-1565nm up to 26dBm, 1535-1565nm up to 41dBm



DATASHEET

Frequency Noise

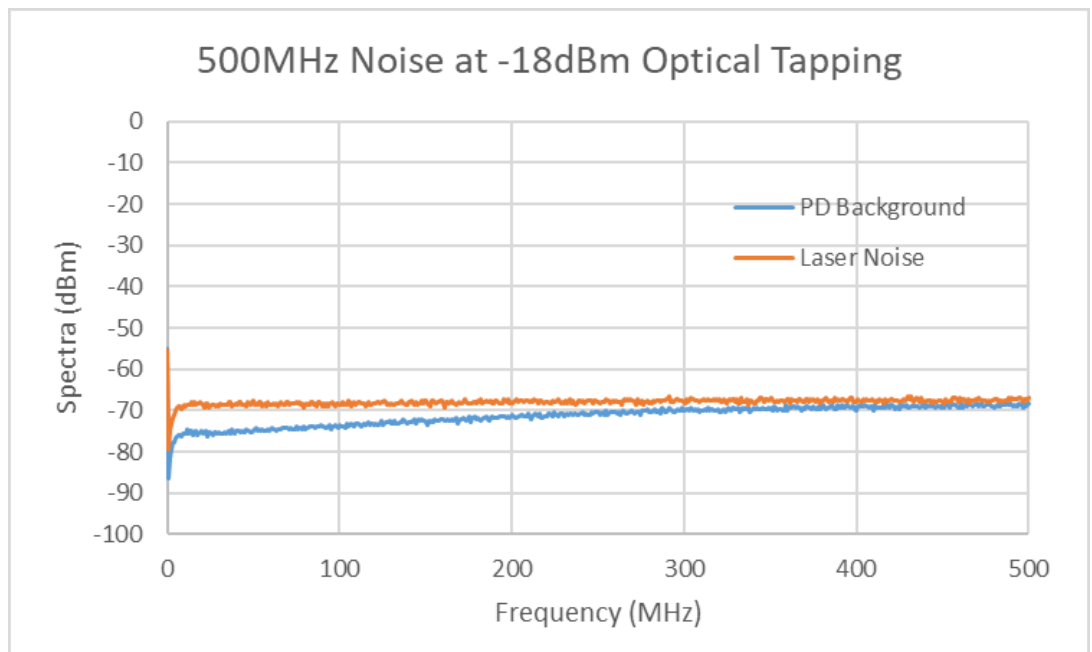
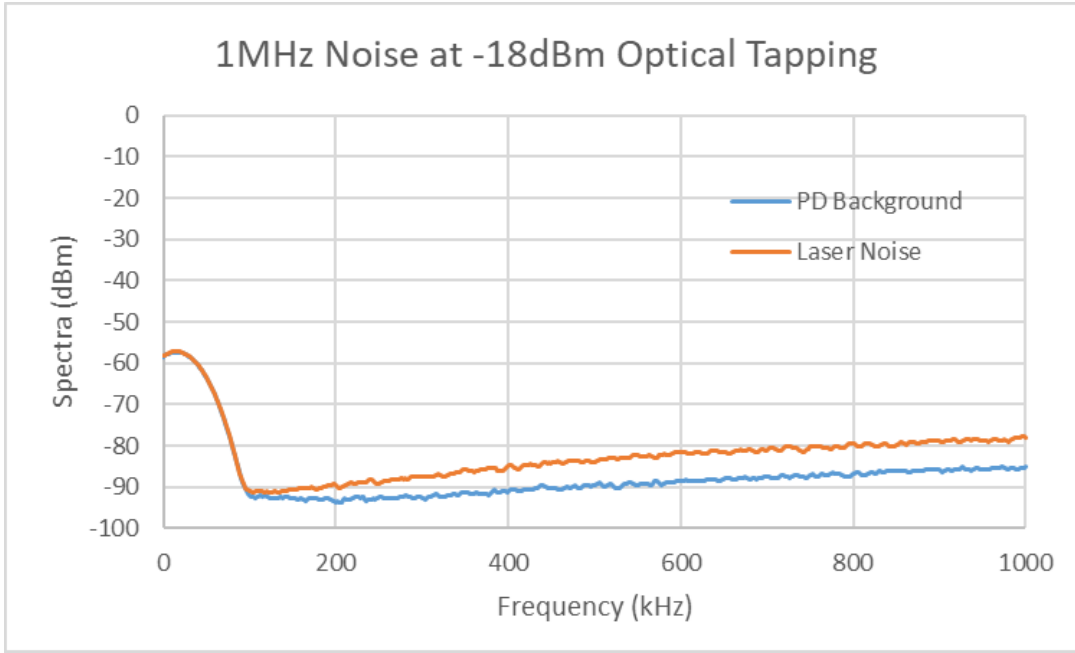

Erbium Doped Fiber Amplifier

1528-1565nm up to 26dBm, 1535-1565nm up to 41dBm



DATASHEET

Frequency Noise

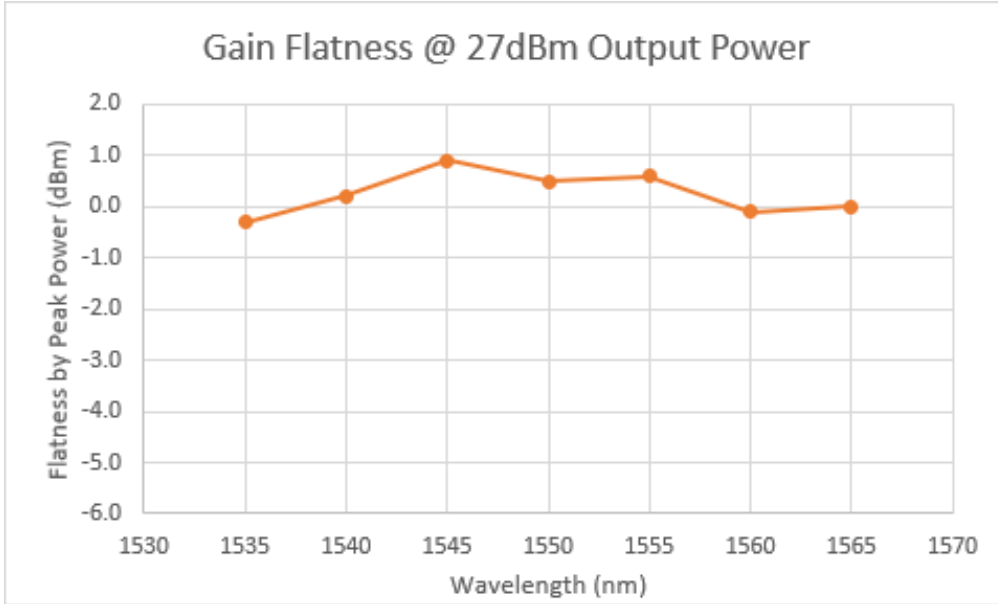

Power Gain

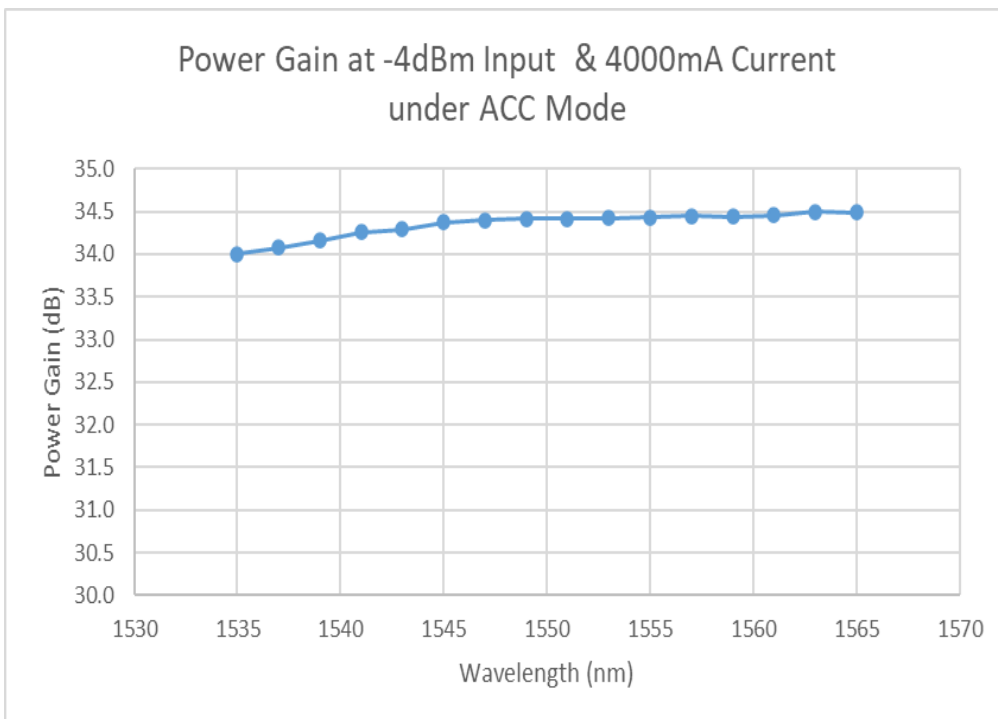

Information contained herein is deemed to be reliable and accurate as of the issue date. Photonwares reserves the right to change the design or specifications at any time without notice. Agiltron is a registered trademark of Photonwares Corporation in the U.S. and other countries.